



 **PLATIPUS**
ENGINEERING SYSTEMS

AN INTRODUCTION TO ENGINEERING SYSTEMS

Platipus Anchors are market leaders in the design, manufacture and marketing of earth anchoring systems for a wide range of engineering applications such as retaining walls, slope stabilisation, erosion control, guyed structures and pipeline anchoring to mention a few.

Our latest range of earth anchoring systems outperform all our previous products.

In our pursuit of excellence, the latest technology is the result of years of experience and high quality Research and Development into the behavioural characteristics of mechanical earth anchors in varying soil conditions.

KEY BENEFITS

- Drastically reduced driving times in a wider variety of soil conditions.
- Significantly increased potential holding capacities in both the 'Stealth' and 'Bat' range of anchors.
- The 'Stealth' range of anchors offers nearly twice or more surface area than previously available anchors, meaning greater holding capacity at the same or lower cost.
- Reduced loadlock and compaction to load distances.

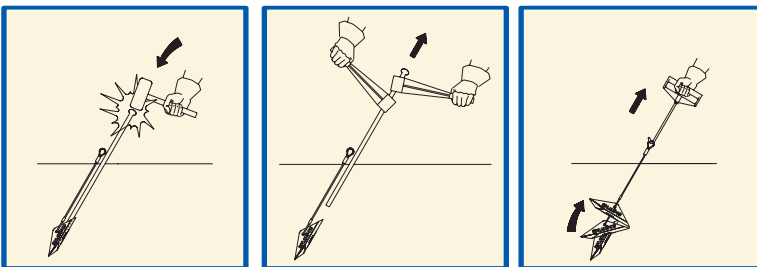

THE PLATIPUS CONCEPT

The Platipus Anchoring System is now well proven and recognised in the field of Engineering as a lightweight, cost effective alternative to traditional methods of anchoring.

Hundreds of thousands of Platipus Anchoring Systems have been successfully installed worldwide in an increasing range of applications.

THE ADVANTAGES

- Significant savings can be achieved over traditional methods in terms of time and money.
- Quick and easy to install using simple tools and plant.
- Ready to use immediately, no waiting time for concrete to cure.
- Light, high capacity anchoring systems available in a wide range of materials and sizes to suit all applications.
- High quality technical support available without charge.
- Tailored designs to meet your unique applications and projects.
- In-house research and development and training facilities.
- All products are designed to relevant British or Internationally accepted standards.
- We are an accredited ISO 9001 company for our quality management and design systems.
- Hundreds of thousands of projects worldwide have been successfully completed over many years.
- All anchor systems can be proof loaded and ready to use in minutes using our powered and manual jacks.



STEALTH



BAT



THE ANCHOR RANGE

Through years of experience and a comprehensive understanding of how the anchors behave in a variety of soil conditions, we are able to utilise our knowledge to further enhance the products we design and manufacture.

Our latest range of 'Stealth' and 'Bat' anchors incorporate some major improvements resulting in reduced driving times, shorter loadlock distances and increased potential holding capacities.

Design improvements include: Angled Winglets, Edge Beads, Delta Drive Point and Bell Shape features.

KEY BENEFITS TO THE INDUSTRY

- The 'Stealth' anchor range offers nearly twice the working surface area of our previous anchor range.
- The 'Bat' anchor range offers enhanced load potential over its predecessor.
- Both new anchors drive faster and straighter through all ground conditions.
- Improved performance of both anchors in a wide variety of materials.
- Mechanical shear failure of the soil is reduced.
- The 'Stealth' and 'Bat' anchors are available in many different formats.
- The same or lower cost for the new system.
- T-Loc option benefits.

BELL SHAPE

The bell shaped working surface area of the anchor offers significant increases in potential load over previous designs. It provides very high load possibilities for a small surface area anchor by focusing the frustum of soil more clearly.

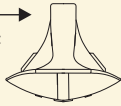

DELTA DRIVE POINT

Where high capacity small profile anchors are used in hard ground conditions it is essential to have a drive point which splits the material by way of separating the upper side and lower side, thus compressing the material into a predetermined area. This enhances the anchor's ability to drive more quickly through dense soil types.

EDGE BEADS

The edges are carefully rounded to further enhance the frustum area and reduce 'spill off' during high loadings which reduces mechanical shear of the soil.

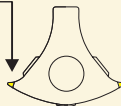

ANCHOR KEEL

The use of a high keel which emanates from the anchor eye to the delta drive point reinforces the ability of the anchor to drive straight through difficult anchoring material.

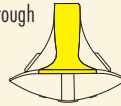
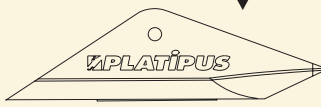

CURVED EXTENDED FRONT WINGS

The forward extension of these wings assists in the loadlocking process, reducing the 'loadlock' distance and enhancing the speed at which the anchor turns.

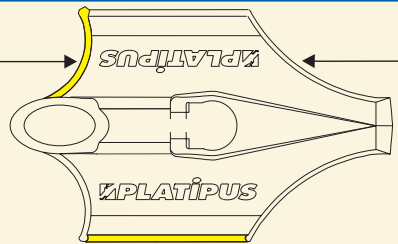

DELTA DRIVE POINT AND TRAILING EDGES

The combination of using the trailing edges in conjunction with a delta drive point enhances the anchor's ability to cut through all variety of anchoring material.

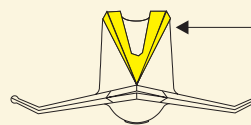

EDGE BEADS

The profile of the edge bead is designed to reduce the mechanical shear of the soil at the wing edge in high load conditions.

ANCHOR KEEL

The use of a high keel which emanates from the anchor eye to the delta drive point reinforces the ability of the anchor to drive straight through difficult anchoring material and protects the tendon from damage.

ANGLED WINGLETS

The angled winglets assist in focusing the main frustum of soil onto the anchor surface itself. Additionally the shape and angle reduces the 'spill off' effect of previous designs, again increasing the potential load.

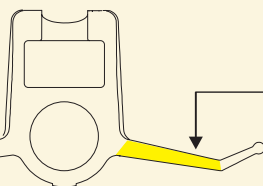

T-LOC SOCKET



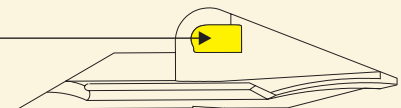

The simple connection provides great flexibility and a wide choice of tendon options.



ANGLED WINGS

When the anchor is in the loadlocked position the angle of the wings increases the overall area of soil frustum by amplifying the angle of interaction, creating increased potential holding capacities.

STEALTH ANCHORS & MATERIALS

E=EYE VERSION	Typical Load Range	Product Code	Materials
	0 - 2.5 kN	S02E	A= Aluminium Alloy H= Hard Anodised
	1 - 10 kN	S04E	A= Aluminium Alloy H= Hard Anodised
	5 - 25 kN	S06E	A= Aluminium Alloy H= Hard Anodised B= Aluminium Bronze
	10 - 40 kN	S08E	A= Aluminium Alloy H= Hard Anodised C= Cast SG Iron B= Aluminium Bronze
T=T-LOC VERSION	Typical Load Range	Product Code	Materials
	20 - 100 kN	S10T	C= Cast SG Iron B= Aluminium Bronze

A = ALUMINIUM ALLOY

Aluminium is an ideal material combining corrosion resistance and considerable strength for use in most soil conditions.





H = HARD ANODISING

Hard anodising is an extension of normal anodising using special techniques to provide an even thicker anodic coating with an even greater abrasion and corrosion resistance.

C = CAST SPHEROIDAL GRAPHITE IRON

Spheroidal graphite iron is a highly ductile form of cast iron suitable for hot dip galvanising. The cast iron and zinc coating offer a very durable solution for medium to long term corrosion resistance.

BAT ANCHORS & MATERIALS

T=T-LOC VERSION	Typical Load Range	Product Code	Materials
	20 - 60 kN	B04T	C= Cast SG Iron B= Aluminium Bronze
	30 - 100+ kN	B06T	C= Cast SG Iron B= Aluminium Bronze
	50 - 150+ kN	B08T	C= Cast SG Iron B= Aluminium Bronze
	75 - 200+ kN	B10T	C= Cast SG Iron B= Aluminium Bronze

B = ALUMINIUM BRONZE

Aluminium bronze is used where there is a requirement for long term applications and/or highly corrosive environments. In some cases aluminium bronze is used in short term applications where the ground is extremely hard and high power installation equipment is required.



The quality and consistency of the soil will affect the typical load range of an anchor considerably.
i) In a cohesive soil (poor soil) the full driven depth may be required to achieve the lowest typical load or less.
ii) In a non cohesive soil (good soil) the shortest driven depth may achieve the highest typical load or more.



LOWER TERMINATIONS

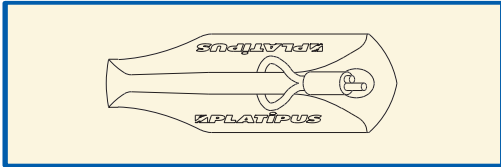

SOFT EYE

The soft eye is formed by feeding the wire tendon through a ferrule, the eye of the anchor and then back through the ferrule again. It is then secured by placing the ferrule into a press and swaging it to a set dimension.

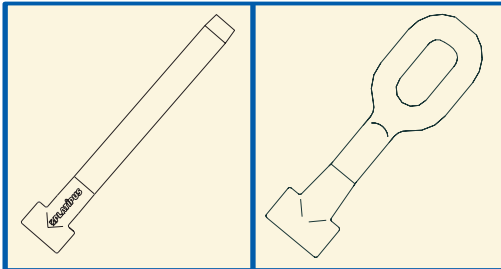

T-LOC/ T-EYE

The main advantage of this type of termination is the flexibility it gives for onsite anchor system assembly.

The 'Stealth' S10 and all sizes of the 'Bat' anchor have been designed to T-Loc specification.

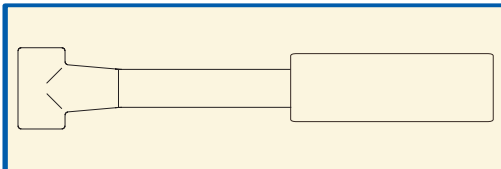

T-KNUCKLE

This fitting, used with a lock nut, enables standard rods to be connected to T-Loc specification anchors.

WIRE TENDONS & MATERIALS

GALVANISED STEEL

All Galvanised Steel wire tendons are manufactured in high carbon steel to BS302 and are hot dip galvanised. They are available in various sizes up to 12mm in diameter and are suitable for temporary short term applications.

LIFE EXPECTANCY = 5 years +

PLASTIC IMPREGNATED STEEL

The herringbone construction used in this type of wire tendon creates larger voids between each strand allowing deep impregnation of polypropylene. They are available in various sizes up to 10mm in diameter and are suitable for medium term applications.

LIFE EXPECTANCY = 40 years +

STAINLESS STEEL

Grade 316 Stainless Steel has the best corrosion resistance of all the standard Stainless Steels. They are available in various sizes up to 12mm in diameter and are suitable for long term applications.

LIFE EXPECTANCY = 100 years +



RODS & MATERIALS

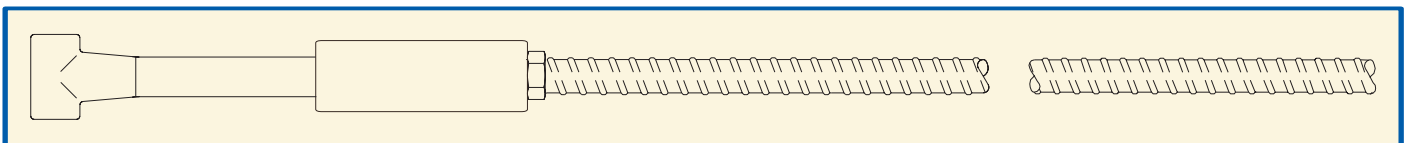

STANDARD STEEL RODS

Standard steel rods are available in various sizes up to 25mm in diameter. They are compatible with the galvanised T-Knuckle lower termination and are suitable for temporary short-term applications.

LIFE EXPECTANCY = 5 years +

GALVANISED STEEL RODS

Available in the same sizes as a standard steel rod. By hot dip galvanising the rods the system becomes suitable for medium term applications.

LIFE EXPECTANCY = 40 years +

STAINLESS STEEL RODS

Available in the same sizes as a standard steel rod. They are compatible with the stainless steel T-Knuckle lower termination and are suitable for long term applications.

LIFE EXPECTANCY = 100 years +

The above figures are a guide only, the exact 'Life Expectancy' of a wire tendon and rod is greatly affected by local soil conditions (e.g. extreme acidic or alkaline soils, chemical presence, stray electrical currents).

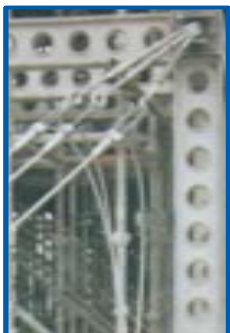

TOP ACCESSORIES

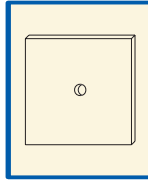

LOAD BEARING PLATE

The load bearing plate is most commonly used in applications where the angle of installation is perpendicular to the structure.

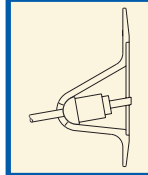

INVERTED SELF ALIGNING PATRESS PLATE

This top accessory is used mostly for projects where the finished appearance is of aesthetic importance, the angle of installation is between 0° to 30° from horizontal and a low non intrusive profile is required.

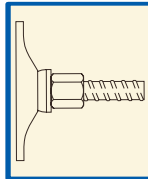

LOADPLATE SET

The Loadplate set is used with rod systems where the angle of installation is perpendicular to the structure.

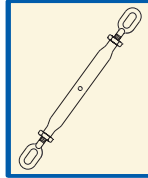

TURNBUCKLE

The turnbuckle is used in guyed applications and is connected to the wire tendon using a hard eye top termination.

TOP TERMINATIONS

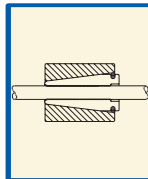

THE WEDGE GRIP

The wedge grip is the most common method of top termination. Consisting of a conically bored steel barrel and three serrated wedges, it transfers the load from the wire tendon to the top accessory.

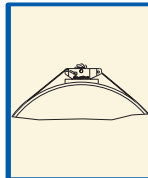

RATCHET TENSIONER

The ratchet tensioner is primarily used with pipeline anchor systems where buoyancy control is a major problem. The ratchet tensioner allows the anchors to be loadlocked preventing any pipe movement.

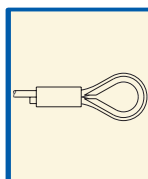

HARD EYE

Anchor systems secured using a hard eye termination can generally be associated with guyed applications.

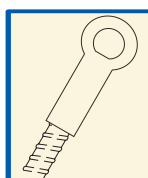

THREADED ROD EYE

The Threaded Rod Eye is a simple fitting used to create an eye at the end of a rod system. It is generally associated with guyed applications.

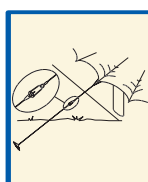

CONICAL WEDGE GRIP AND BAIL

The conical wedge grip grips the wire tendon in a similar way to a standard wedge grip. Comprising of a collar, bail and conical wedge grip, it is used to create an eye at any point along an open tail wire tendon.

PLATIPUS ENGINEERING SYSTEMS

INSTALLATION

MAIN STAGES OF INSTALLATION

There are three main stages to the installation of an anchor system.

- 1. DRIVING THE ANCHOR:**
Drive the anchor system into the ground to the required installation depth.
- 2. REMOVING THE RODS:**
Remove the drive rod from the body of the anchor, either by hand or by using special rod removing equipment.
- 3. LOADLOCKING:**
Loadlock the anchor into its working position by applying a load to the wire tendon.

The anchor system can be installed using a variety of light, medium or heavy installation equipment. As the requirement for anchor size and placement depth increases it is essential to utilise larger installation equipment. All the relevant power sources and plant are readily stocked by most plant hire companies.

LIGHT INSTALLATION

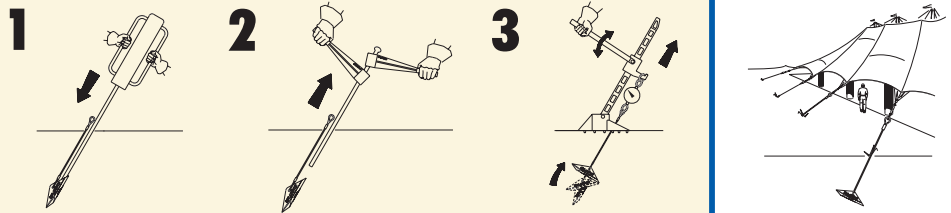

MEDIUM INSTALLATION

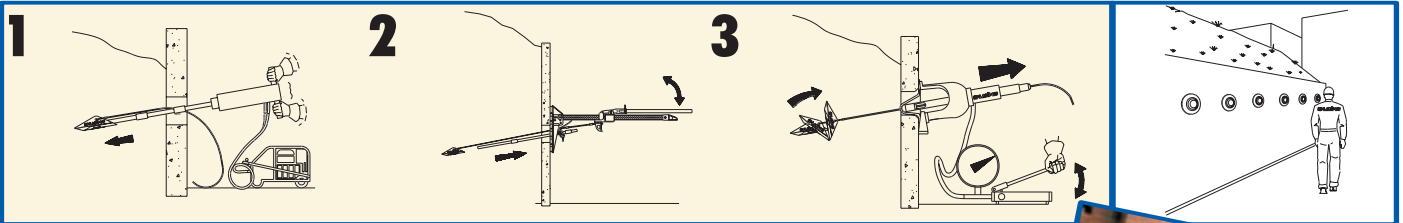

HEAVY INSTALLATION

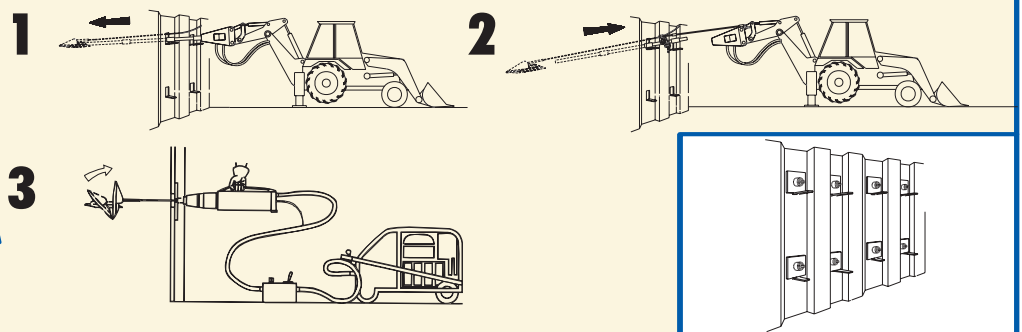

PLATIPUS ANCHORS LIMITED, Kingsfield Business Centre, Philanthropic Road, REDHILL, Surrey, RH1 4DP, England.

Tel: +44 (0) 1737 762300 Fax: +44 (0) 1737 773395

Web: www.platipus-anchors.com E-Mail: info@platipus-anchors.com

Reg. No. 1680529 England - Quality Management and Design Systems to ISO 9001 - Reg. EAQA/75

PLATIPUS ENGINEERING SYSTEMS

DRIVE RODS

A wide range of drive rods are available to either purchase or hire in various lengths ranging from 1 metre to 3 metres in 25, 32 and 38mm diameters.

We manufacture shanks for most types of powered installation equipment as well as a complete range of one piece drive rods for simple tasks.

Should you require it, a complete list and specification of all our drive rods is available upon request.



POWERED EQUIPMENT

Over the years, we have utilised Stanley hydraulic tools and can highly recommend their systems.

Additionally, their light weight, flexibility and significant power outperforms many conventional compressed air systems.

A wide range of suitable plant is available from most plant hire companies.

LOADLOCKING/STRESSING

The main advantage to our anchor system is the ease with which they can be loadlocked and proof loaded.

We design and manufacture a range of manual and powered equipment to suit all applications.

Stanley hydraulic equipment is also used to power most our own loadlocking and stressing equipment.



TOOLS

In many cases only the basic tools and equipment is required to install and loadlock most anchor systems.

We also produce a complete range of tools and special equipment to speed up and assist multiple anchor installations.

PLATIPUS ANCHORS LIMITED, Kingsfield Business Centre, Philanthropic Road, REDHILL, Surrey, RH1 4DP, England.

Tel: +44 (0) 1737 762300 Fax: +44 (0) 1737 773395

Web: www.platipus-anchors.com E-Mail: info@platipus-anchors.com

Reg. No. 1680529 England - Quality Management and Design Systems to ISO 9001 - Reg. EAQA/75

KEY INFORMATION

Before we can determine the most suitable anchor system, we must receive some 'Key Information' concerning the project and the application.

In some situations, it may be necessary to carry out a Site Analysis and Load Test Report to accurately determine the holding capacity of the proposed anchor system. Once this has been completed, positive anchor system recommendations can be made.

In addition, our team of Regional Sales Managers are available to assist you in incorporating Platipus anchor systems into your own schemes and guide you from project enquiry to completion.

KEY INFORMATION

- The proposed application
- Time scales of the project
- Confirmation drawings and plans
- Ultimate and working loads
- Factor of safety
- Soil type and its condition
- Placement of the slip plane, if applicable
- Life expectancy of the application
- Location of buried services and obstructions
- Angle of installation
- Quantity of anchors to be installed
- Accessibility to the site



PERFORMANCE

Capacities of the anchor system depend at all times on the quality and consistency of the material into which they are placed.

Soil conditions vary throughout the world and it is necessary in all cases to assess the quality of the anchorage through testing procedures.

The performance of the anchor system is based upon the following factors:

- The shear angle of the soil
- The size of the anchor
- The depth of installation
- The load applied



LOADLOCKING

Due to the shape of the anchor and the offset attachment point of the wire tendon, when a load is applied the anchor will rotate in the ground up to 90° and loadlock.

In a dry granular material the anchor will normally loadlock within its own body length. In a saturated clay material you can expect this loadlock distance to increase by three times.

Every anchor system must be fully loadlocked and is normally proof loaded prior to being put into service.

As the load exerted on the soil by the anchor system increases, a body of soil ahead of the anchor system is compressed and provides resistance to any further anchor movement. The size and spread of this body of soil can be visualised as being a truncated cone or frustum. We refer to this soil as the Frustum Cone.

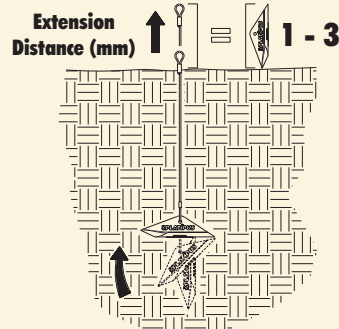

FRUSTUM CONES

The size and spread of a Frustum Cone will depend upon:

- The shear angle of the soil
- The size of the anchor
- The depth of installation
- The load applied

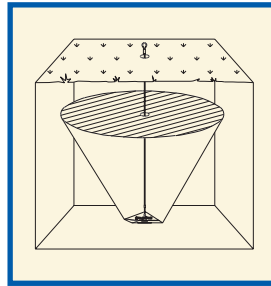

Cohesive Soil (Poor Soil)

In a typical cohesive soil, the clay mineral particles are of 'Plate-like' form. The space between each of the 'Plates' contains water which dissipates when subjected to load. Gravelly or sandy silts and clays are generally of this composition.

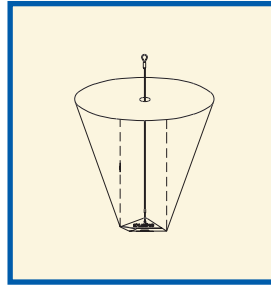

Non-Cohesive Soil (Good Soil)

A typical non-cohesive soil consists of different sized particles which interlock, bond and compact when subjected to a load. Course sands and gravels are generally of this composition.

Our anchor systems perform exceptionally well in free draining non-cohesive soil, displaying shorter loadlock and extension characteristics than in a cohesive saturated clay.

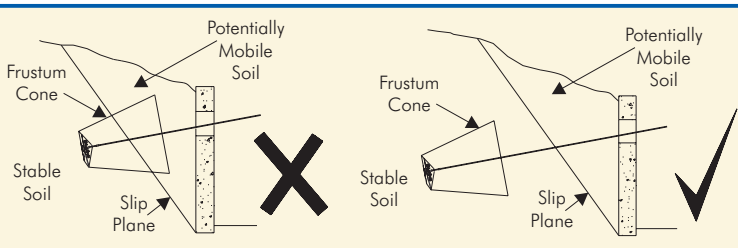
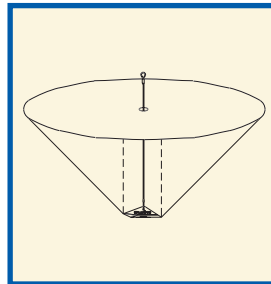

SLIP PLANES

With unsupported soil structures such as steep embankments, cuttings and deep trenches, there is a potential risk of slip or collapse. The failure surface between the slipped material and the undisturbed material is referred to as the Slip Plane.

When designing an earth retaining structure to prevent such failures the Design Engineer will determine the slip plane position based on analysis of site and soil investigations, and soil properties data. The Design Engineer can then specify the anchor system installation depth and required holding capacity.

For an anchor system to work effectively it must be driven far enough beyond the predicted slip plane, to allow the frustum cone to work independently in stable soil. Then if a slip in the soil were to develop there would be no reduction in the frustum cone size and the load achieved.

Some guidelines for the minimum installation depth required to allow the anchor system to generate its frustum cone and work independent of the slip plane are provided in the adjacent table.

ANCHOR SIZE	RECOMMENDED MINIMUM DEPTH BEYOND THE SLIP PLANE
S02	0.3 - 0.4m
S04	0.6 - 0.75m
S06	0.8 - 1.2m
S08	1.1 - 1.5m
S10	2.0 - 3.0m
B04	1.5 - 2.5m
B06	2.0 - 3.0m
B08	3.0 - 4.0m
B10	4.0 - 5.0m

The final installed depth is subject to site test and should be revised, if necessary, once the site test has been completed and firm data on the load and extension has been established.

PLATIPUS ENGINEERING SYSTEMS

LIFE EXPECTANCY

It is important to establish exactly how long the anchor system is going to be in use. This, linked with information about corrosive properties of the soil, will clearly indicate the correct choice of materials to use.

A sign of life expectancy can also be measured by the anchor system's application. For example, a temporary sheet pile retaining wall will normally only require galvanised materials. The only exception to this would be if the soil was very corrosive.



BURIED SERVICES

Information of buried services such as gas, electric, water and telecommunications over the proposed site should be clearly identified so that anchor installations do not clash with them.

If documented details are not available then an examination of the site will often reveal the location of inspection hatches and valve covers. This will give an indication of the depth of the services and the direction they run.

ABOUT THE COMPANY

Platipus have supplied mechanical anchors to the Civil Engineering, Landscaping and Utility industries for over 20 years. Our headquarters in Redhill, Surrey, England are home to our Sales & Marketing team, Research & Development Department, in-house Training facility and our Manufacturing operation.



RESEARCH & DEVELOPMENT

Working closely with our own team of engineers and existing distributors, product modifications, enhancements and new system designs are constantly being evaluated and introduced into the market.

Many new and differing applications for our products are becoming increasingly apparent throughout the world. By using Computer Aided Design we can provide clients with unique solutions, quickly and efficiently.



TRAINING

In addition to high quality, effective products, we place great emphasis on Customer Training and Product Support. To enable us to achieve this, we have established our own Training Centre to provide comprehensive training for distributors, licensees and clients.

To suit individual requirements, we can also offer tailor made training and product demonstrations on site, normally at no extra charge.



ISO 9001



We are pleased to operate the necessary standards to maintain ISO 9001 for both our QUALITY MANAGEMENT AND DESIGN SYSTEMS

PATENTS & TRADEMARKS



Worldwide patents are applicable on a variety of products. Additional patents pending. The trademark 'PLATIPUS' is registered worldwide. All patents and trademarks are the sole property of the company.

PLATIPUS ANCHORS LIMITED, Kingsfield Business Centre, Philanthropic Road, REDHILL, Surrey, RH1 4DP, England.

Tel: +44 (0) 1737 762300 Fax: +44 (0) 1737 773395

Web: www.platipus-anchors.com E-Mail: info@platipus-anchors.com

Reg. No. 1680529 England - Quality Management and Design Systems to ISO 9001 - Reg. EAQA/75



 **PLATIPUS**
ENGINEERING SYSTEMS